

HSX 100 - 105000/2

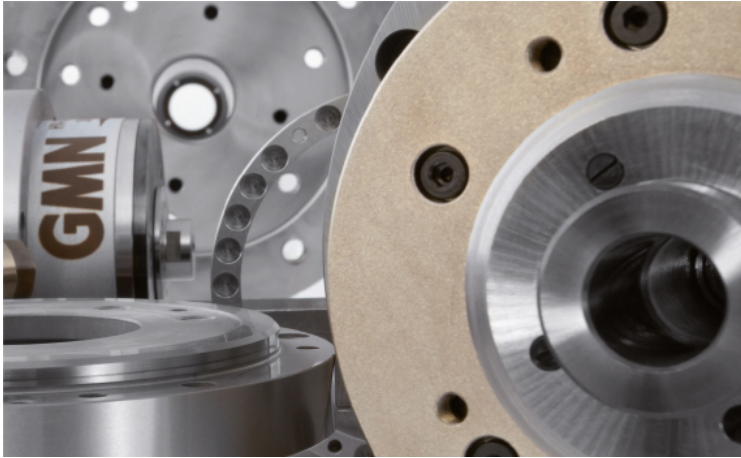

Technical data		
∅ Spindle housing	A	[mm]
Speed max.	n_{max}	[min^{-1}]
Bearing; front	W_1	[mm]
Tool interface		
∅ Flat layout	W	[mm]
Static rigidity		
axial	C_{ax}	[N/ μm]
radial	C_{rad}	[N/ μm]
Motor realization		
Frequency max.	f_{max}	[Hz]
Converter voltage ¹⁾		[V]
Power	P_{S1}	[kW]
Torque	M_{S1}	[Nm]
... at speed	n	[min^{-1}]
Current	I_{S1}	[A]
Power	$P_{S6-60\%}$	[kW]
Torque	$M_{S6-60\%}$	[Nm]
... at speed	n	[min^{-1}]
Current	$I_{S6-60\%}$	[A]

HSX 100 - 105000/2		
100		
105000		
15		
D 08/14		
14		
26		
29		
200 V	350 V	-
1750		
200	350	-
1,7		
0,155		
105000		
8,8	5	-
2		
0,182		
105000		
11	6,5	-

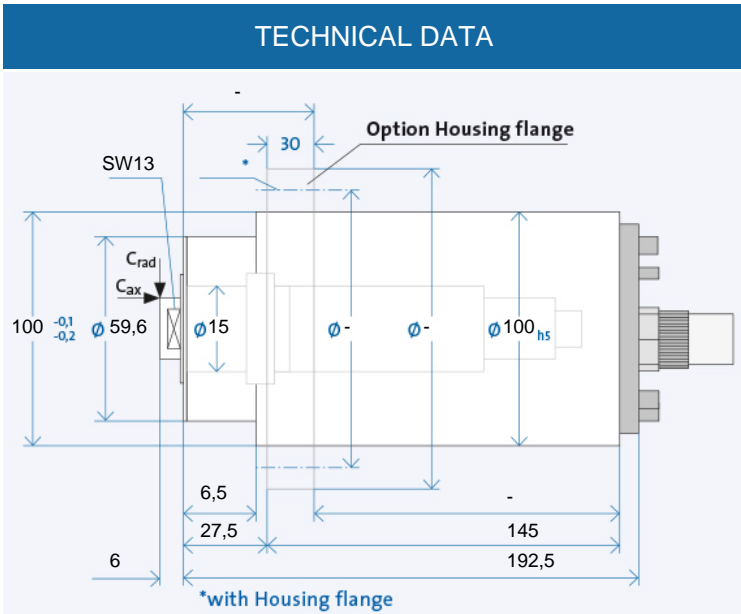

Electrical connection		
Plug type		
Straight plug connection		
Coil plug connector		
Fixed cable XXm		
Coolant feed through the shaft		
Low pressure (du)		
High-pressure (dh)		
Sensors		
Rotary encoder		
Speed sensor		
Housing		
Cylindrical housing		
Cylindrical housing with flange		
Block housing		
Air-tight seal		

GA	GA	-
+	+	-
o	o	-
o	o	-
Coolant feed through the shaft		
	o	
	-	
Sensors		
	-	
	+	
Housing		
	+	
	o	
	x	
	o	

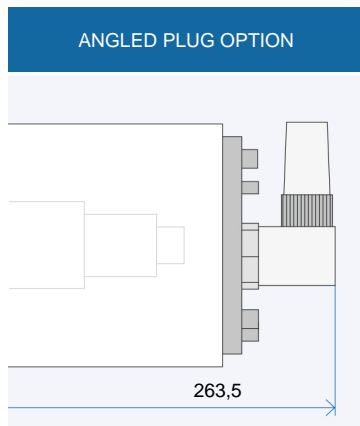
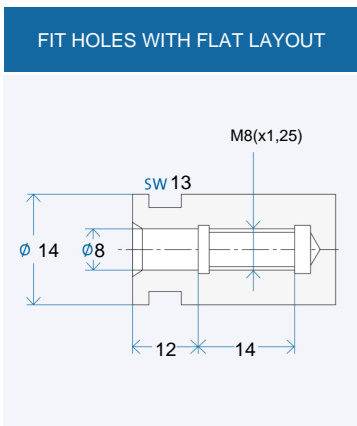

¹⁾ Minimum required starting voltage for the frequency converter.

- + Standard
- o Optional
- x Upon request

Ordering information:
 HSX 100 - 105000/2
 R is for clockwise, L for counter-clockwise
 + Desired options

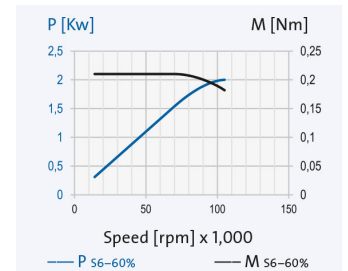

The data currently provided on the internet apply. Further and detailed information is provided in the GMN 2508 catalogue.

HSX 100 - 105000/2

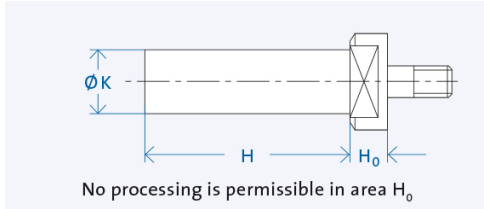

Semi-finished goods

GMN semi-finished products allow the individual adaptation of the tool interface for any connections.

d ₁	K [mm]	H [mm]
D 08/14	14	70

Ordering information: »Semi-finished goods« [Shaft Ø K] x [Shaft length H] [Interface]
 Example: Semi-finished goods 34 x 180 D16/33



Lubrication system

The electronically controlled PRELUB lubrication unit is optimally adapted to the oil-air lubricated GMN spindles and guarantees a long service life.



Cooling system

GMN cooling units ensure precisely adjustable temperature and quantity delivery of the coolant and achieve consistently low operating temperatures.



Cable and plug

Ready-made cables with B048, B049, GA, MAC, D500 and STK plugs are available on request. For the spindle/converter connection, GMN supplies UL/CSA approved electrical cables suitable for use in drag chains.