

# TSP 100 x 355

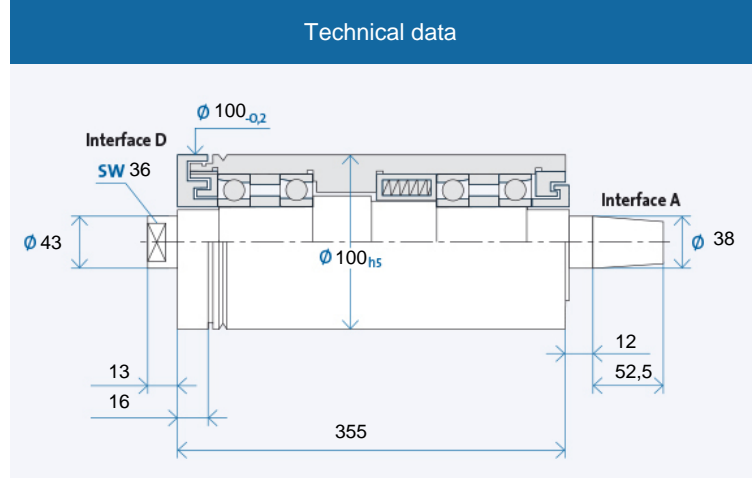

Maximum speed $n_{max}$ [min-1]* for bearing types:	
Steel (steel)	15000
Hybrid (optional)	20000

\* without tool

Ordering information: TSP 100 x 355 R is for clockwise, L for counter-clockwise

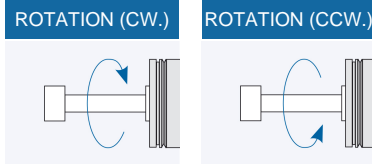

## Accessories

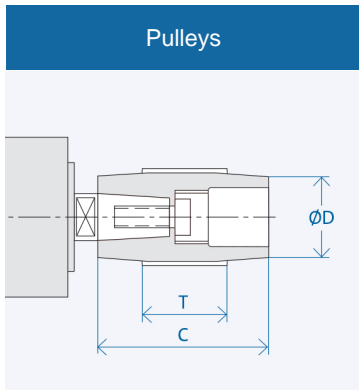

Interface	Dimensions [mm]		
	D	C	T
A 38	50	80	60
	63	80	60
	160	80	60

Ordering information pulley: AX<sub>1</sub>-X<sub>2</sub>

X<sub>1</sub>: Interface: 10/13/...

X<sub>2</sub>: Figure from column D

Puller for pulley: AX<sub>1</sub>/...

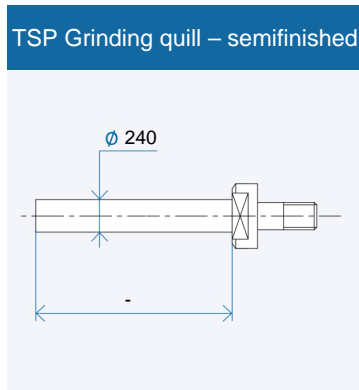

Ordering information semifinished: DX<sub>1</sub>/X<sub>2</sub>  
X<sub>1</sub>/X<sub>2</sub>: Interface 08/14/...

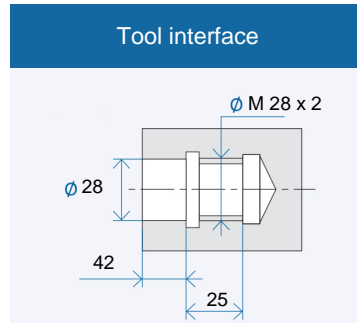

Tool interface: fitting bores with flat contact face acc. to GMN precision standards

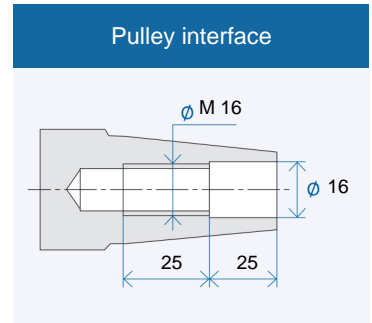

Pulley interface: taper 1 : 7,5 nominal value, included angle acc. to GMN precision standards